



INSTRUCTION BULLETIN

No. 9012958
Machine: T17
Published: 06-2014
Rev. 00

NOTE: DO NOT DISCARD the Parts List from the Instruction Bulletin. Place the Parts List in the appropriate place in the machine manual for future reference. Retaining the Parts List will make it easier to reorder individual parts and will save the cost of ordering an entire kit.

NOTE: Numbers in parenthesis () are reference numbers for parts listed in Bill of Materials.

Installation instructions for **kit number 9020260**

SYNOPSIS:

This kit contains the parts needed to replace the ec- H2O module in T17 scrubbers.
Please follow step-by-step instructions.

SPECIAL TOOLS / CONSIDERATIONS: NONE

(Estimated time to complete: 45 minutes)



PROTECT THE ENVIRONMENT

Please dispose of packaging materials, used machine components such as batteries and fluids in an environmentally safe way according to local waste disposal regulations.

Always remember to recycle.

PREPARATION:

1. Park the machine on a clean level surface, turn off the machine, set the parking brake, and remove the key.

FOR SAFETY: Before leaving or servicing machine, stop on level surface, turn off machine, set parking brake, and remove key.

2. Disconnect the battery cable from the machine.



WARNING: Always disconnect battery cables from machine before working on electrical components.

INSTALLATION:

1. Open the right shroud to access the ec- H2O module.
2. Disconnect the main wire harness from the ec- H2O module.
3. Disconnect the ec- H2O module hoses from the machine. Set the hose clamps aside.
4. Remove the ec- H2O module from the machine. Set all mounting hardware aside.
5. Measure the lengths of both hoses on the ec- H2O module removed from the machine and cut the hoses on the new ec- H2O module (1) to the same lengths. (Fig. 1)
6. Install the new ec- H2O module (1) into the machine. Connect the hoses to the solution supply quick disconnect and the scrub head quick disconnect. (Fig. 1)

7. Connect the main wire harness to the new ec- H2O module (1).
8. Reconnect the battery cable to the machine.

9. Start and test the machine. Check for error codes and ensure the ec- H2O system is functioning.

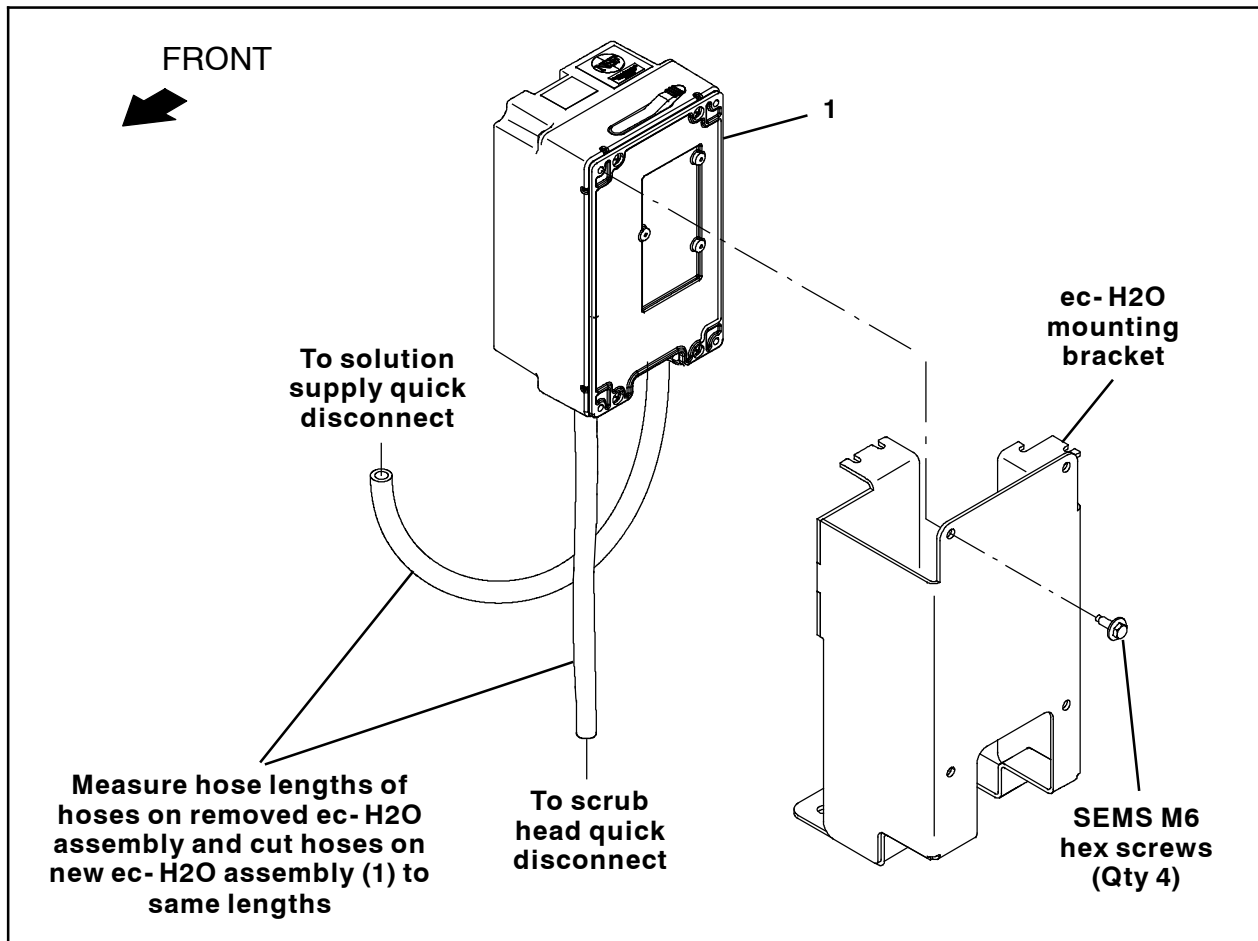

FIG. 1

Bill Of Materials For ec- H2O Module Kit, Afmkt [Mod- E] - 9020260

Ref.	Tennant Part No.	Description	Qty.
▽	9020260	ec- H2O Module Kit, Afmkt [Mod- E]	1
▲	1 1212103	Module, Ele [ec- H2O, Mod- E]	1

TENNANT COMPANY
P. O. Box 1452
Minneapolis, MN 55440-1452